

BINKS[®]

Instruction Manual

For

E2-30 Electric Drive Pump

- **Model 107071 (EU Model)**
- **Model 107074 (USA Model)**
- **Model 107075 (Japan Model)**

E2-40 Electric Drive Pump

- **Model 107093 (EU Model)**
- **Model 107094 (USA Model)**
- **Model 107095 (Japan Model)**

Note: Read and follow all instructions and safety precautions before using this equipment

Product Description

107071 – E2-30 Electric Pump
107093 – E2-40 Electric Pump



This equipment is designed for use with Solvent based and Waterborne materials.
Suitable for use in Zone 1 and 2, Protection Level: **II 2 G X**

Manufacturer: - Binks PCE
Justus-von-Liebig-Straße 31,
63128 Dietzenbach. DE

EU Declaration of Conformity

We: Binks declare that the above product conforms with the Provisions of Machinery Directive 2006/42/EC and the ATEX Directive 94/9/EC by complying with the following statutory documents and harmonized standards: -

Machinery Safety Standards EN ISO 12100, EN ISO 4413, EN ISO 4414 & EN12621
Explosion Prevention Potentially Explosive Atmospheres EN 1127-1
Non-electrical Equipment for Potentially Explosive Atmospheres BS EN 13463-1
Constructional Safety for Potentially Explosive Atmospheres EN 13463-5

Providing all conditions of safe use stated within the product manuals have been complied with and that the final equipment into which this product is installed has been re-assessed as required, in accordance with essential health and safety requirements of the above standards, directives and statutory instruments and also installed in accordance with any applicable local codes of practice.

A handwritten signature in black ink, appearing to read 'H. Beiersdorfer'.

H Beiersdorfer (General Manager)
8th January 2010

Index

Section

- 1.1 General Description
- 1.2 Operating Principle
- 1.3 Specifications
- 1.4 Dimensions and Mounting Details

- 2.1 Important Safety Information

- 3.1 Installation - General
- 3.2 Installation – Electrical / Grounding
- 3.3 Installation – Mechanical

- 4.1 Operation

- 5.1 Parts List – Main Assembly
- 5.2 Parts Lists – Mechanical Assembly
- 5.3 Parts Lists – Fluid Section Assembly

- 6.1 Maintenance - Assembly Procedure
- 6.2 Maintenance – General
- 6.3 Maintenance - Motor / Gearbox
- 6.4 Maintenance - Fault Finding
- 6.5 Maintenance – Testing / Lubrication / Draining

- 7.1 Spare Parts Lists

- 8.1 Accessories

General Description – Section 1.1

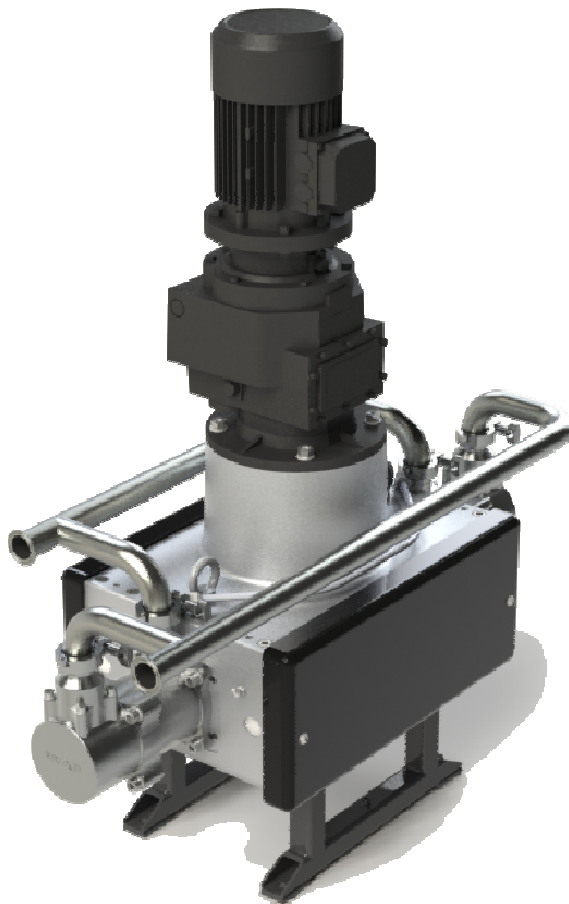

The E2-30 pump uses a standard EExd 4 pole AC electric motor to drive the fluid section, for pumping paints, solvents and other suitable materials.

The unit combines conventional electrical hardware to achieve optimum operating performance at a lower cost. Running costs are much lower than compressed air driven models.

The Model E2-30 Electric Pump achieves a reciprocating drive by using a cam and cam followers combined with a sliding carriage unit.

Equal thrust on each stroke together with the special cam profile reduces fluid pressure fluctuations to an absolute minimum.

The operating speed is adjusted by an AC frequency inverter between 20 and 80 HZ and can be adjusted infinitely within this working range.

Complies with current relevant European and US Legislation

Patents Granted

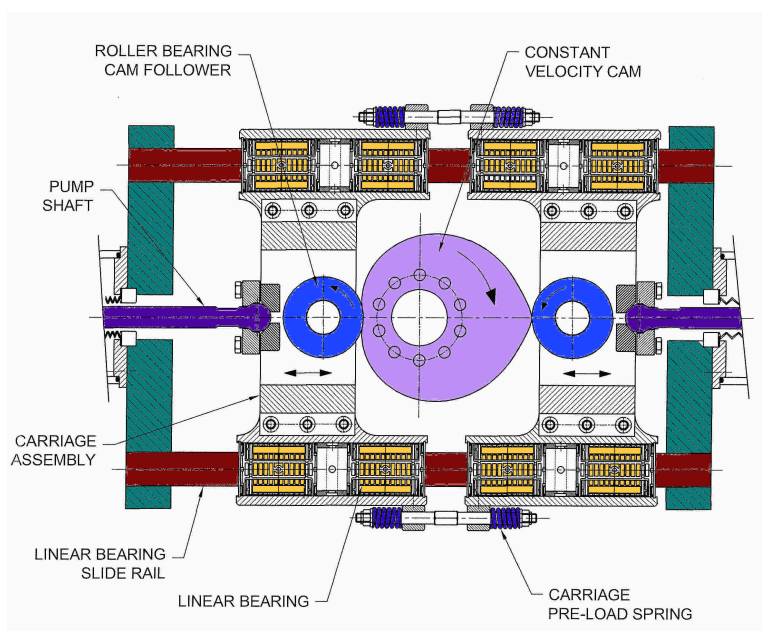

Operating Principle – Section 1.2

The Assembly comprises of:-

- 1 off Electric Motor
- 1 off In Line Gearbox
- 1 off Drive Shaft / Cam assembly
- 2 off Cam Follower / Carriage assembly
- 2 off Fluid Pistons
- 2 off Fluid Pressure Chambers
- 1 off Fluid Inlet Manifold
- 1 off Fluid Outlet Manifold
- 2 off Support Stand

An AC Induction electric motor drives the fluid section via a mechanical gearbox. The electric motor speed is controlled by an AC Frequency inverter, which can adjust the frequency between 20 and 80 Hz, this being the certified range of the electric motor. The speed adjustment is made by control of the Inverter Frequency Output through manual operation or from a PLC analogue output. The motor frequency is directly proportional to the Fluid Output, (see specifications).

The gearbox is directly coupled to a drive shaft onto which a cam is mounted. As the cam is rotated one of two diametrically opposed fluid displacement pistons is pushed via a connecting rod and cam follower / carriage assembly producing the pressure stroke.

At the same time the other fluid piston is pulled by the opposed cam follower / carriage assembly producing the suction stroke.

Each of the two carriage assemblies are held in place by 4 compression springs in order to maintain a constant connection between the cam follower bearings and the cam.

Ball checks control the fluid flow into and out of the pressure chambers during these operations.

Operating Principle – Section 1.2

The Piston Assembly is a unique design as this has the Inlet ball built in to save on space.

The outlet ball check is spring assisted to minimise pressure drop at change over.

A bellows provides the fluid seal on the connecting rod within the inlet chamber, whilst a piston lip seal maintains the pump fluid pressure within the pressure chamber.

If the main piston seal starts to pass fluid due to wear, any leakage passes into the inlet chamber.

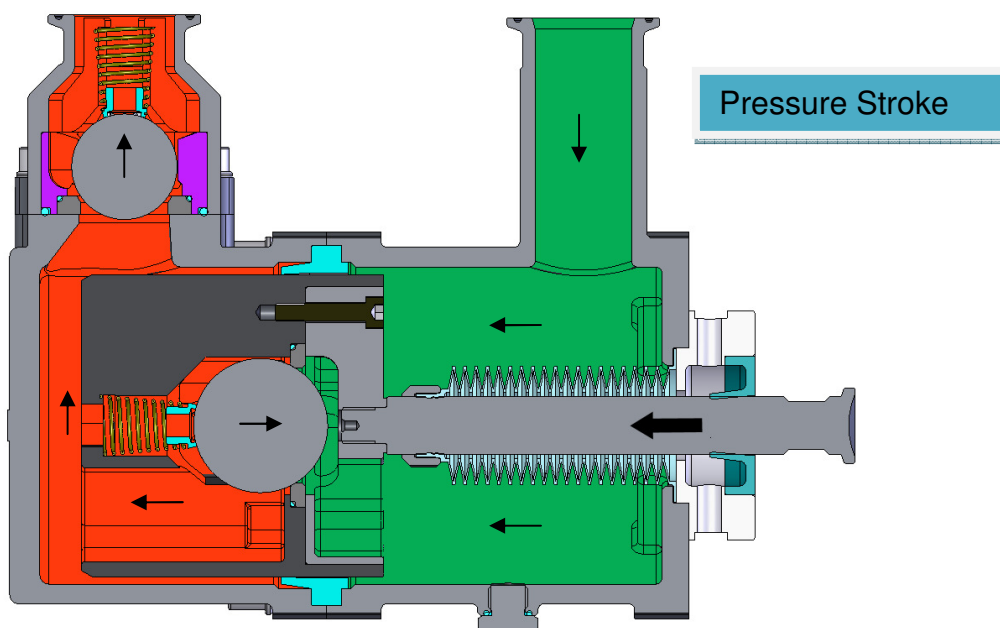
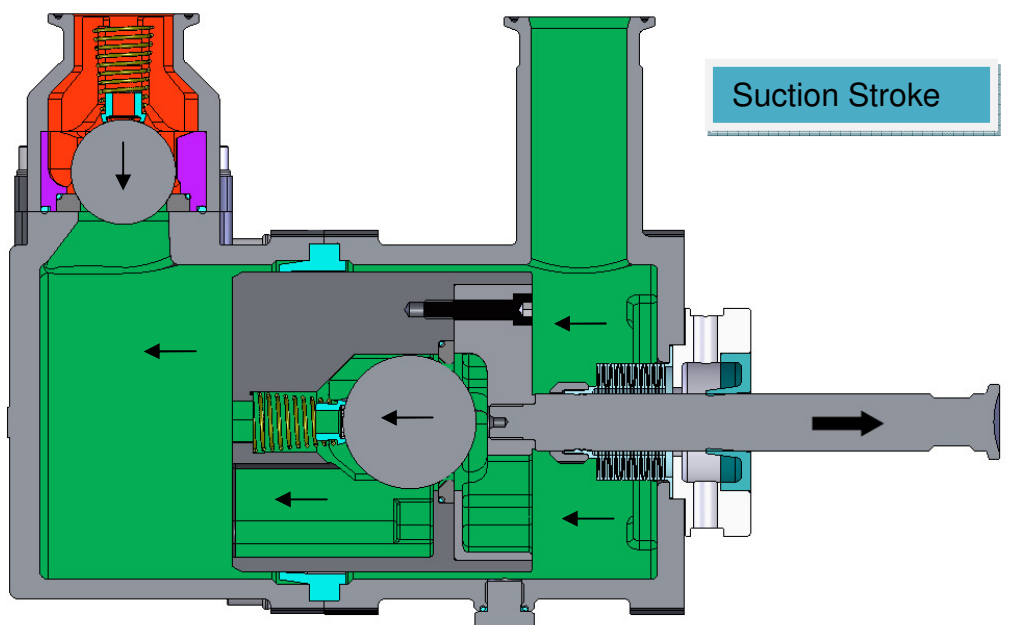

Specification – Section 1.3

Specification	
Pump Nominal Stroke	50 mm (1.97 ins)
E2-30 Maximum Fluid Pressure	18 bar (261 psi)
E2-40 Maximum Fluid Pressure	14 bar (203 psi)
E2-30 Nominal Flow Volume / Cycle	0.75 Litres (0.20 US Gall)
E2-40 Nominal Flow Volume / Cycle	1.00 Litre (0.26 US Gall)
E2-30 Fluid Output @ 20 HZ (10 cycles/min)	7.5 Litres / min (2.0 US Gall / min)
E2-40 Fluid Output @ 20 HZ (10 cycles/min)	10 Litres / min (2.64 US Gall / min)
E2-30 Fluid Output @ 80 HZ (40 cycles/min)	30.0 Litres / min (8.0 US Gall / min)
E2-40 Fluid Output @ 80 HZ (40 cycles/min)	40.0 Litres / min (10.6 US Gall / min)
Fluid Inlet / Outlet Connections	1 1/2" Sanitary
Gearbox Ratio	56:1
Gearbox Oil Quantity (EP ISO VG 220 Mineral Oil) (EU Model)	3.70 Litres (0.90 US Gall)
Gearbox Oil Quantity (SHC 630 Synthetic Oil) (USA Model)	3.70 Litres (0.90 US Gall)
AC Induction Electric Motor -EU Model 1.5 kW 4Pole 1400 RPM 90L (1.5 kW 4Pole 1400 RPM 90L Japan Model)	400V 3PH 1.5 kW @ 50HZ EEx d 11B T3 Rated 20 to 80 Hz (with thermisters)
AC Induction Electric Motor - USA Model	460V 3PH 2 Hp @ 60HZ Class 1, Group D. Rated 20 to 80 Hz (c/w thermostats)
Total Weight of Pump (inc electric motor)	250 Kg (550 Lb)

Dimensions and Mounting Details – Section 1.4

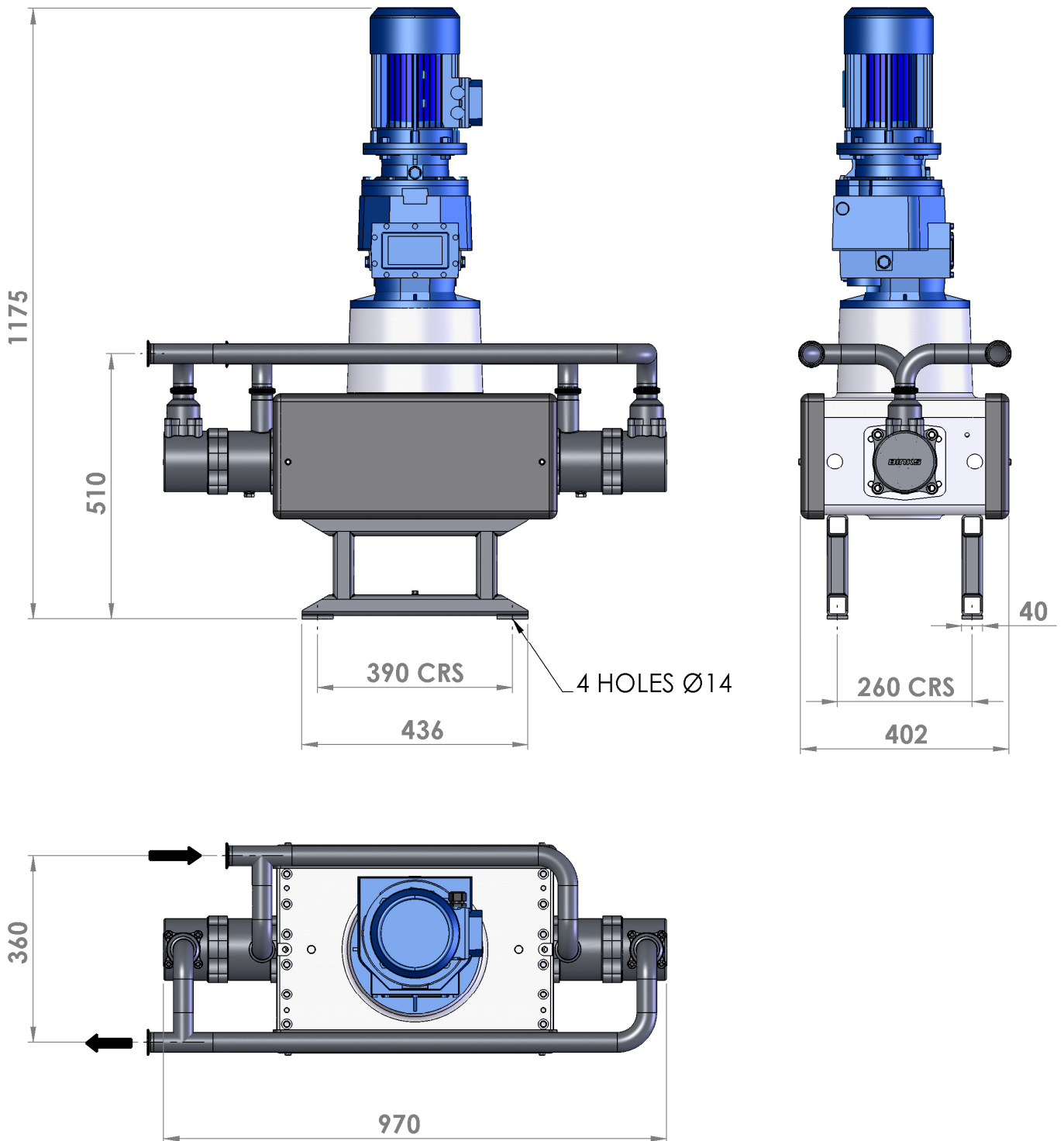

Important Safety Information - Section 2.1

Directions for Working Safety

This Product has been constructed according to advanced technological standards and is operationally reliable. Damage may, however, result if it is used incorrectly by untrained persons or used for purposes other than those for which it was constructed.

The locally current regulations for safety and prevention of accidents are valid for the operation of this product under all circumstances.

International, national and company safety regulations are to be observed for the installation and operation of this product, as well as the procedures involved in maintenance, repairs and cleaning.

These instructions are intended to be read, understood and observed in all points by those responsible for this product. These operating and maintenance instructions are intended to ensure trouble free operation. Therefore, it is recommended to read these instructions carefully before start-up. Binks PCE cannot be held responsible for damage or malfunctions resulting from the non-observance of the operating instructions. These instructions including regulations and technical drawings may not be copied, distributed, used for commercial purposes or given to others either in full or in part without the consent of Binks. We reserve the right to alter drawings and specifications necessary for the technical improvement of this product without notice.

High Pressure/Electrostatic Warning

High pressure equipment can be dangerous if used incorrectly, serious bodily injury may occur if the following instructions are ignored. Installation and maintenance should only be carried out by suitably qualified personnel.

1. Before attempting any work on a high-pressure system ensure material pump, hydraulics, compressed air motor are isolated where relevant.
 2. Relieve all pressure from the system. Note: It is possible for pressure to get locked into a system, therefore, ensure all sections of the system are checked thoroughly for remaining pressure.
 3. Take care when releasing fittings
 4. Always replace worn hoses immediately
 5. Never plug a leak with your finger, adhesive tape or other stop gap devices
- Always ensure equipment is suitably earthed before running, to avoid any chance of electrostatic build up.

Equipment Misuse Hazard

Equipment misuse can cause the equipment to rupture or malfunction and result in serious injury.

- This equipment is for professional use only.
- Read all instruction manuals, tags, and labels before operating the equipment.
- Use the equipment only for its intended purpose.
- Do not alter or modify this equipment. Use only genuine Binks parts and accessories.
- Check equipment daily. Repair or replace worn or damaged parts immediately.
- Do not exceed the maximum working pressure stated on the equipment or in the Technical Data for your equipment. Do not exceed the maximum working pressure of the lowest rated component in your system.
- Use fluids and solvents which are compatible with the equipment wetted parts. Refer to the Technical Data section of all equipment manuals. Read the fluid and solvent manufacturer's warnings.
- Route hoses away from traffic areas, sharp edges, moving parts, and hot surfaces. Do not expose hoses to temperatures above 82°C (180°F) or below -40°C (-40°F).
- Wear hearing protection when operating this equipment.
- Do not lift pressurized equipment.
- Comply with all applicable local, state, and national fire, electrical, and safety regulations.

Important Safety Information - Section 2.1

Fire, Explosion and Electric Shock Hazard

Improper grounding, poor ventilation, open flames or sparks can cause a hazardous condition and result in a fire, explosion, or electric shock.

When installed and operated in accordance with its instructions, the Pump is approved for operation in Zone 1 (Europe) & Division 1 (North America), hazardous locations. (ATEX Cat 2)

- Electrical equipment must be installed, operated, and serviced only by trained, qualified personnel who fully understand the requirements stated in this instruction manual.
- Ground the equipment and all other electrically conductive objects in the spray area.
- Keep all covers in place while the motor is energized.
- If there is any static sparking or you feel an electric shock while using this equipment, stop spraying/dispensing immediately. Do not use the equipment until you identify and correct the problem.
- Provide fresh air ventilation to avoid the build up of flammable fumes from solvents or the fluid being pumped.
- Keep the pumping area free of debris, including solvent, rags, and gasoline.
- Electrically disconnect all equipment in the pumping area.
- Extinguish all open flames or pilot lights in the spray/dispense area.
- Do not smoke in the spray/dispense area.
- Do not turn on or off any light switch in the spray/dispense area while operating or if fumes are present.
- Do not operate a gasoline engine in the spray/dispense area.

Hot Surface Hazard

- The electric motor becomes hot during operation, and the heat may be transferred to other connected equipment. To reduce the risk of burning yourself, do not touch the motor surfaces while it is operating. Before servicing, allow the motor to cool.
- Keep flammable materials and debris away from the equipment.

Pressurized Equipment Hazard

Spray from the gun/valve, hose leaks, or ruptured components can splash fluid in the eyes or on the skin and cause serious injury.

- Do not point the gun/valve at anyone or at any part of the body.
- Do not stop or deflect leaks with your hand, body, glove or rag.
- Follow the Pressure Relief Procedure whenever instructed to relieve pressure; stop spraying/dispensing; clean, check, or service the equipment.
- Tighten all fluid connections before operating the equipment.
- Check the hoses, tubes, and couplings daily. Replace worn, damaged, or loose parts immediately. Permanently coupled hoses cannot be repaired; replace the entire hose.

Toxic Fluid Hazard

Hazardous fluid or toxic fumes can cause serious injury or death if splashed in the eyes or on the skin, inhaled, or swallowed.

- Know the specific hazards of the fluid you are using.
- Store hazardous fluid in an approved container. Dispose of hazardous fluid according to all local, state and national guidelines.
- Always wear protective eyewear, gloves, clothing and respirator as recommended by the fluid and solvent manufacturer.

Moving Parts Hazard

Moving parts, such as the cam and drive mechanism, can pinch or amputate your fingers.

- Keep clear of all moving parts when starting or operating the pump.
- Never remove the drive section cover while operating the pump.

Installation – Section 3.1 - General

The E2-30 & E2-40 Pump Units are designed for location in Zone 1 Hazardous areas, ATEX Category 2. Electrical connections must be in accordance with Local regulations for installation in Hazardous areas.

It is recommended that a Local Control Box is positioned in close proximity to the pump, as a convenient local Start / Stop facility and Junction box. The main Pump Control Panel must be positioned within an Electrically Safe Area.

A Pressure switch (and/or Pressure relief valve) must be connected to the outlet manifold port and set to stop the pump (or relieve the fluid pressure) in the event of the system overpressure e.g. blocked paint filter. This is necessary to protect the Pump mechanics from overload. An adapter to mount a pressure switch and pressure sensor is available, see accessories.

It is recommended that the switch setting is set to 1 bar (14.5 psi) above the maximum required pressure. The maximum Pressure setting the pressure switch should be set to is 19 bar (275 psi) and 14 bar (203 psi) respectively.

The pressure switch must be fitted and functioning correctly before the pump is put into use otherwise Pump warranty may be invalidated.

The Pressure Switch is classified as simple apparatus and as such should be electrically connected as part of an intrinsically safe electrical circuit. The pressure switch should be wired as a Normally Closed contact (fail safe) and be hard wired to stop the motor on operation, to minimise response time.

Electric Motor

Motor must be wired to provide a clockwise direction of the cam. Electric Motors for hazardous areas are specially designed to comply with official regulations concerning the risk of explosion. If improperly used, badly connected, or altered no matter how minor, their reliability could be in doubt. Standards relating to the connection and use of electrical apparatus in hazardous areas must be taken into consideration. Only trained personnel familiar with these standards should handle this type of apparatus.

The Pump Frame must be wired to a suitable earth ground to ensure that there is no possibility of static build up

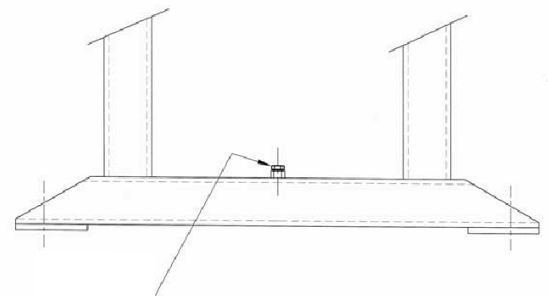

M6 HEX. HEAD SCREW FOR PUMP EARTH GROUNDING

Installation – Section 3.2 - Electrical

Inverter

The pump cycle rate and thus the fluid output is controlled by adjusting the motor speed, this is achieved by changing the electrical frequency input to the motor between the range of 20 and 80 Hz.

A suitable 3PH AC inverter must be used to control the motor speed,

Where the customer provides a suitable inverter then the following parameters are to be used.

Important! The electric motor is certified for use in a hazardous area between frequencies of 20 Hz an 80 Hz, therefore it is essential that this range cannot be inadvertently exceeded by the operator as this will invalidate the certification and use of the electric motor.

Required European Inverter Settings	Value
Maximum Hz output	80 Hz
Minimum Hz output	20 Hz
Acceleration Ramp	5 Seconds
Deceleration Ramp	0.1 Seconds
Rated Motor Power	1.5 kW
Rated Motor Current	3.8 A
Rated Motor Voltage	400 V
Rated Motor speed	1440 RPM
Rated Motor Power Factor	0.81
Rated Motor Efficiency	78 %
Rated Motor Frequency	50 Hz

Application Criteria

In a general manner inverters can be connected directly to the power supply line without line reactors. But in this case, ensure the following:

To prevent damage to the inverter and to ensure its expected life, minimum line impedance that introduces a voltage drop of 1%, as a function of the motor load, should be used. If the line impedance (transformers + wirings) is lower than these values, it is recommended to use line reactor.

Installation – Section 3.2 – Electrical

Smart Control - Optional

The pump can be used in either flow mode or pressure mode. When Pressure mode is required it is desirable to use a 'Smart card' to control the functionality of the pump.

The control card has in built software to control the paint flow rate and system pressure within given set parameters so that the paint system can be used in the most efficient way at all times, thus saving energy consumption.

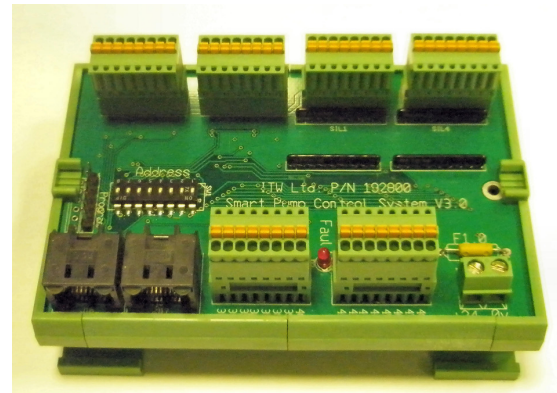

Smart Control

The 'Smart' system design provides for two modes of operation, fully automatic closed loop pressure control and open loop flow control.-

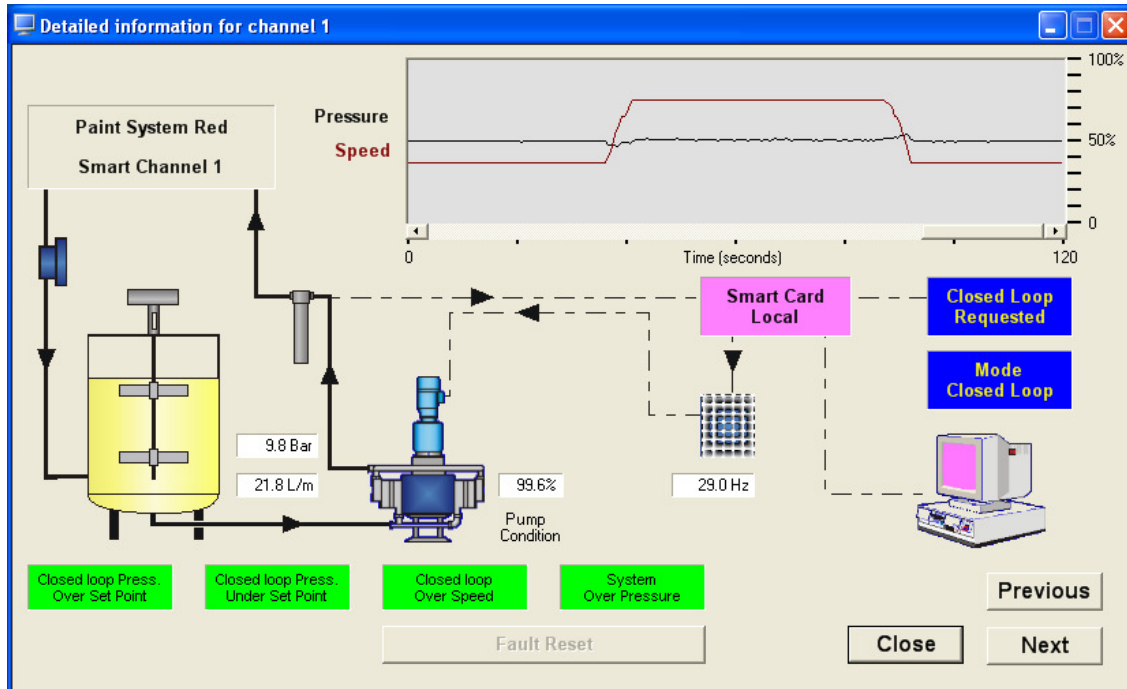

Detailed Status for 1 Channel showing 20L/min flow increase in the paint system and the immediate pump speed response increase

Installation – Section 3.3 - Mechanical

- Secure the Pump assembly to the floor (or purpose designed support steelwork) using the 4 off Ø13 mm holes in the base of the pump support frame.
- Attach suitable hoses (20 bar maximum working pressure) to the inlet and outlet connections. E.g. 50 mm NB Inlet and 38 to 50 mm NB Outlet hose.
- In addition to the pressure switch a Pressure relief valve can be connected and piped back to the pump supply tank to relieve pump outlet pressure in the event that the pipework system is closed (by ball valve or other means) causing system overpressure.
This is necessary to protect the Pump mechanics from overload and subsequent damage.
It is recommended that the relief valve setting is set to 1 bar (14.5 psi) above the maximum required pressure. The maximum Pressure setting the relief valve should be set to is 1 bar (14.5 psi) above pump maximum working pressure.

A pressure sensor is utilised when the pump is set up in 'Pressure Mode' (instead of 'Stroke Mode') where the pump cycle rate is adjusted to respond to paint system pressure, a dedicated 'Smart Card' or PLC software should be incorporated in the pump control system to ensure correct operation.

- Ensure adequate air space around the Pump for maintenance and electric motor cooling requirements.
- Check that the oil plug on top of Gearbox has been replaced with the correct venting plug. The vent plug is supplied in a bag attached to the gearbox.
- Ensure the gearbox is filled with oil. (The gearbox is filled with the correct amount of oil at the factory)

Operation - Section 4.1

System Operation

Before starting: -

- Ensure all electrical and mechanical connections are correctly made.
- All required interlocks are tested and operational.
- Suitable material for pumping is available at the suction hose.
- The outlet connection is not blocked or isolated by any valves.
- Check the gearbox oil level, top up as necessary with the correct grade (see maintenance section) and that the gearbox ventilator is fitted.

Set the pump speed to the minimum frequency 20 HZ and start the pump to remove any air from the circuit. Inspect for any leaks.

Set the pump cycle rate to achieve the required paint volume and then adjust the system back pressure regulator to achieve the desired system fluid pressure. Refer to Fluid Output Table for comparison of fluid output relative to Inverter frequency and Pump cycle rate.

The return line ‘back pressure’ regulator responds to the changes in system fluid flow demand, (due to variable paint usage) by dynamically adjusting the paint flow rate returning to the system paint tank, thus maintaining the set pressure.

Motor Speed Fluid Output Table					
Motor Speed HZ	Pump Speed Cycles/min	Fluid Flow Rate Litres/min	Fluid Flow Rate US Gall/min	Fluid Flow Rate Litres/min	Fluid Flow Rate US Gall/min
		E2-30 Pump		E2-40 Pump	
20	10.0	7.50	2.0	10.0	2.64
25	12.5	9.38	2.5	12.5	3.30
30	15.0	11.25	3.0	15.0	3.96
35	17.5	13.13	3.5	17.5	4.62
40	20.0	15.00	4.0	20.0	5.28
45	22.5	16.88	4.5	22.5	5.94
50	25.0	18.75	5.0	25.0	6.61
55	27.5	20.63	5.5	27.5	7.27
60	30.0	22.50	6.0	30.0	7.93
65	32.5	24.38	6.5	32.5	8.59
70	35.0	26.25	7.0	35.0	9.25
75	37.5	28.13	7.5	37.5	9.91
80	40.0	30.00	8.0	40.0	10.57

Parts List – Section 5.1

Parts List – E2-30 & E2-40 Main Pump Assembly				
ITEM	PART No	DESCRIPTION	QTY	REMARKS
1	-- -- --	MECHANICAL DRIVE ASSEMBLY	1	E2-30 & E2-40
2	192680	FLUID SECTION ASSEMBLY	2	E2-30
2	192755	FLUID SECTION ASSEMBLY	2	E2-40
120	192669	H063 ATEX GEARBOX (EU)	1	107071 / 93 PUMP
120	<i>192670</i>	<i>H063 GEARBOX (USA PUMP)</i>	<i>1</i>	<i>107074 / 94 PUMP</i>
120	<i>192756</i>	<i>H063 STANDARD GEARBOX (JAPAN)</i>	<i>1</i>	<i>107075 / 95PUMP</i>
121	192666	1.5 KW ATEX ELECTRIC MOTOR (EU)	1	107071 / 93 PUMP
121	<i>192667</i>	<i>2 HP ELECTRIC MOTOR (USA PUMP)</i>	<i>1</i>	<i>107074 / 94 PUMP</i>
121	<i>192664</i>	<i>1.5 KW ELECTRIC MOTOR (JAPAN)</i>	<i>1</i>	<i>107075 / 95PUMP</i>
122	164470	M12 WASHER ST ST	4	
123	163126	M12 HEXAGON NUT	4	
124	192634	MOUNTING FRAME	2	
125	165100	M16 SPRING WASHER	4	
126	165588	M16 x 30 CAP HD SCREW	4	
127	165044	M12 SPRING WASHER (ST ST)	8	
128	165960	M12 x 40 CAP HD SCREW (ST ST)	8	
129	192592	1 1/2" SAN INLET MANIFOLD	1	
130	192593	1 1/2" SAN OUTLET MANIFOLD	1	
131	192008	1 1/2" SANITARY GASKET PTFE	4	1 2 3 4
132	192009	1 1/2 SANITARY CLAMP	4	
133	192591	COVER	2	
134	164474	M8 x 16 TORX SCREW (ST ST)	4	
135	192485	M8 WASHER (NYLON)	4	

Parts List – Section 5.1

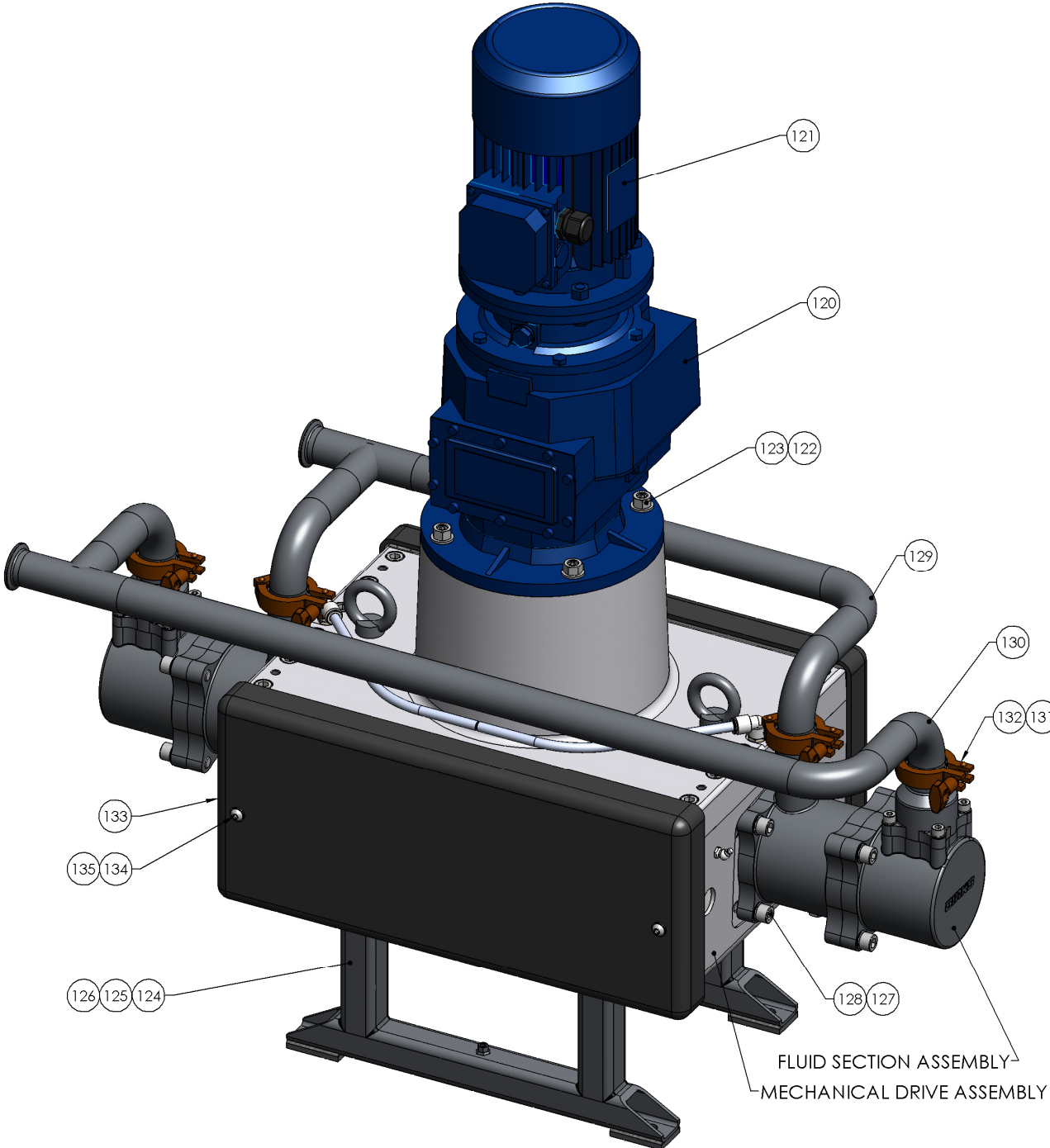

Parts List – Mechanical Assembly				
ITEM	PART No	DESCRIPTION	QTY	REMARKS
10	192599	BASE PLATE	1	
11	192598	TOP PLATE	1	
12	192653	Ø12 x 30 DOWEL PIN	4	
13	163161	M8 NYLOC NUT	4	
14	165552	M8 x 20 CAP HD SCREW	8	
15	165663	M8 x 30 GRUBSCREW (ST ST)	4	
16	165686	M12 x 50 SK HD GRUBSCREW	4	
17	165571	M10 x 70 CAP HD SCREW	10	
18	163952	M6 x 20 CAP HD SCREW (ST ST)	12	
19	165087	M6 SPRING WASHER (ST ST)	12	
20	165960	M12 x 40 CAP HD SCREW (ST ST)	12	
21	192644	Ø80 SHAFT SEAL	1	⑦
22	192640	Ø100 ROLLER BEARING	1	⑦
23	192616	BEARING CAP	1	
24	192645	O-RING Ø100 x 2.5	1	⑦
25	192650	1/8 x 45 GREASE NIPPLE	3	
26	192617	TOP BEARING CAP	1	
27	192639	Ø110 BALL BEARING	1	⑦
28	192594	TOP SHAFT	1	
29	192600	CV CAM*	1	
30	192606	BASE SHAFT	1	
31	192655	M45 BEARING LOCKNUT	1	
32	192656	M50 BEARING LOCKNUT	1	
33	192661	1/8R - 6MM PUSH IN ELBOW	2	
34	192643	LINEAR BEARING ROD	2	⑥
35	192441	M16 EYE BOLT	2	
36	192637	SPACER - COVER	4	
37	192440	O-RING Ø10.46 X 5.33	4	
38	192671	12 x 8 x 40 LG ROUND EDGE KEY	1	
39	192589	COUPLING ASSEMBLY	1	(192590 SPIDER)
40	192682	CARRIAGE ASSEMBLY	2	
41	193105	SPRING KEEP	4	
42	193102	CARRIAGE SPRING ROD	2	
43	193104	CARRIAGE SPRING	4	⑤
44	192400	SPRING RETAINING WASHER	4	
45	192751	HOSE PLUG	1	
46	192752	1/4 – 10mm PUSH IN ELBOW	2	
47	192753	Ø10 x 6 PU HOSE	2	
48	192668	SHAFT CLAMP ASSY	2	
49	192662	Ø6 GREASE HOSE	2	⑤ Fit to 33 & 76

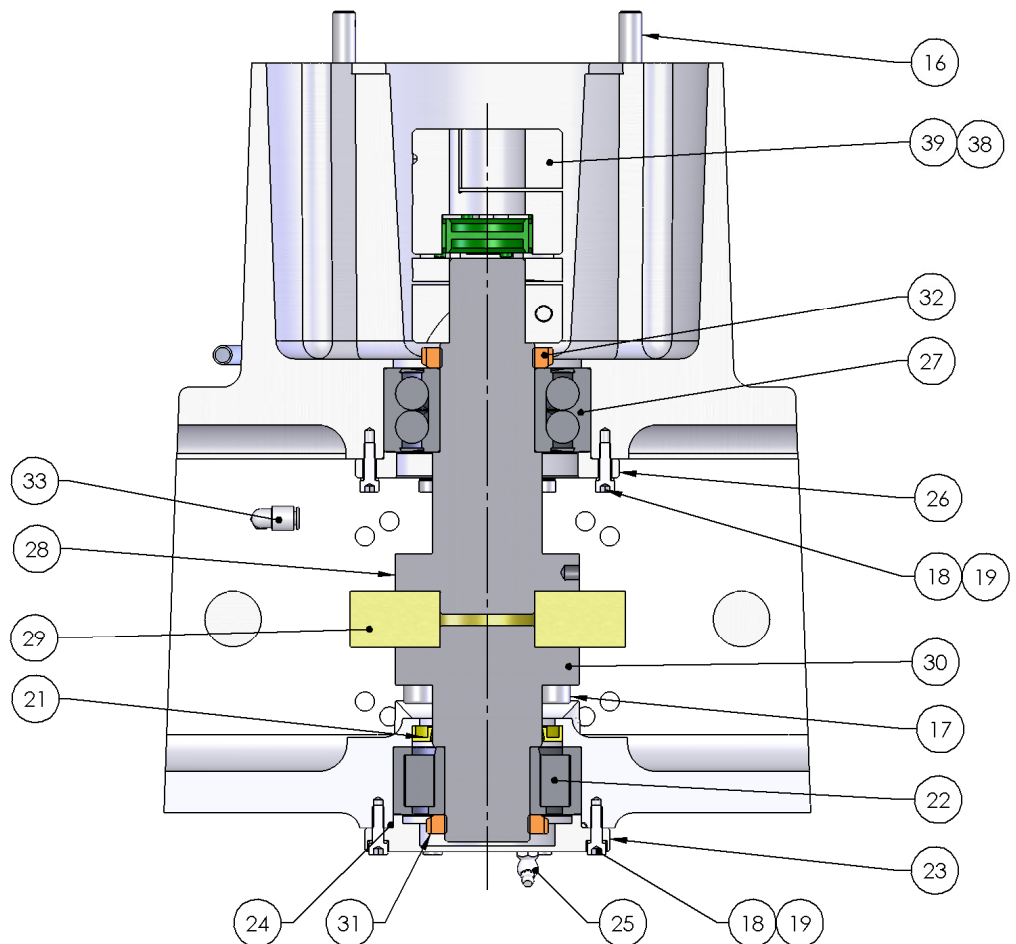
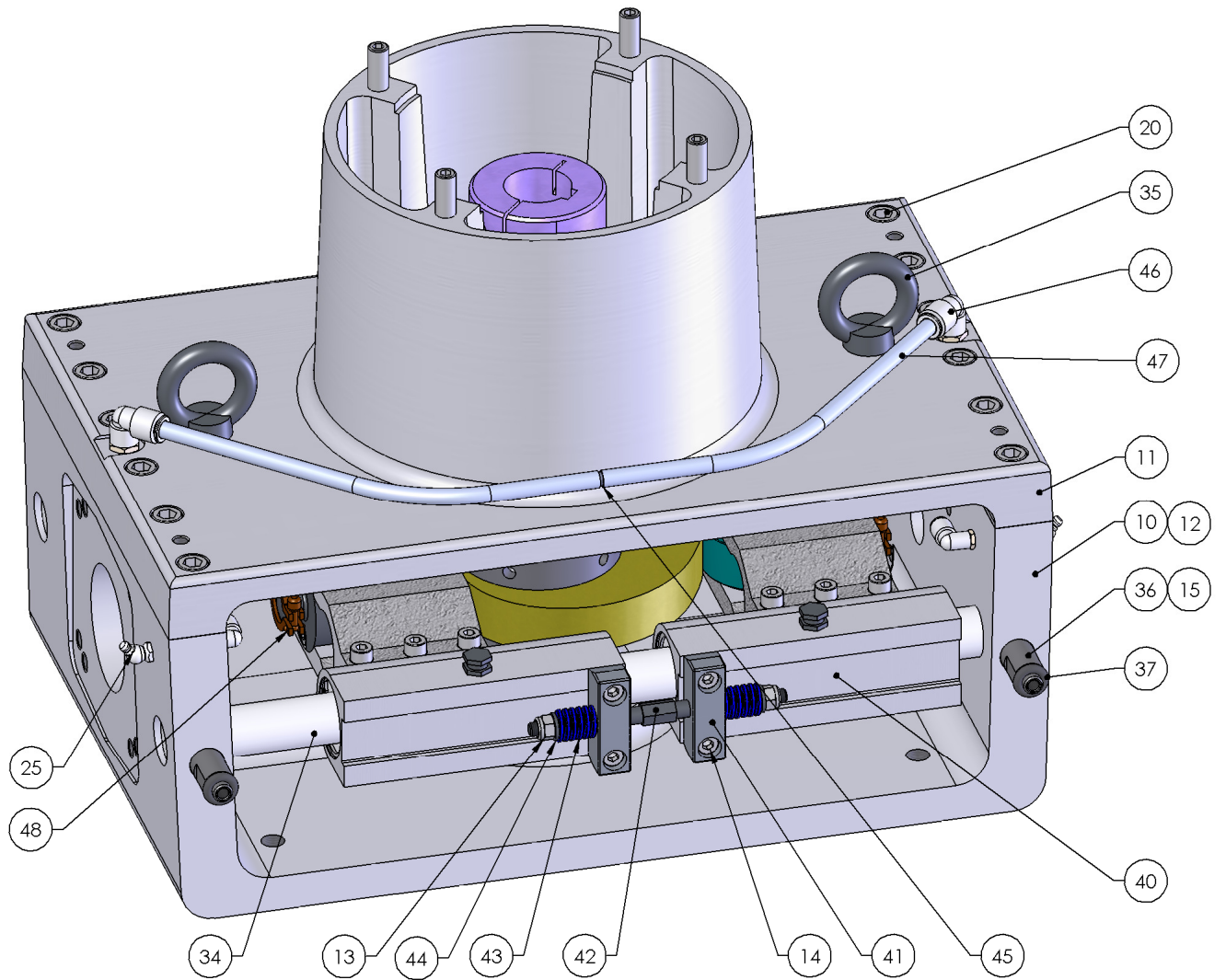

Parts List – Section 5.2

Parts List – Mechanical Assembly - Carriage 192682				
ITEM	PART No	DESCRIPTION	QTY	REMARKS
60	192608	LH CARRIAGE END	1	
61	192607	CARRIAGE MIDDLE	1	
62	192609	RH CARRIAGE END	1	
63	192618	CARRIAGE ADAPTOR	1	
64	192611	FOLLOWER GUARD WASHER	2	Ⓢ
65	192610	CAM FOLLOWER PIN	1	
66	192612	FOLLOWER NUT WASHER	1	
67	192641	Ø72 CAM FOLLOWER	1	Ⓢ

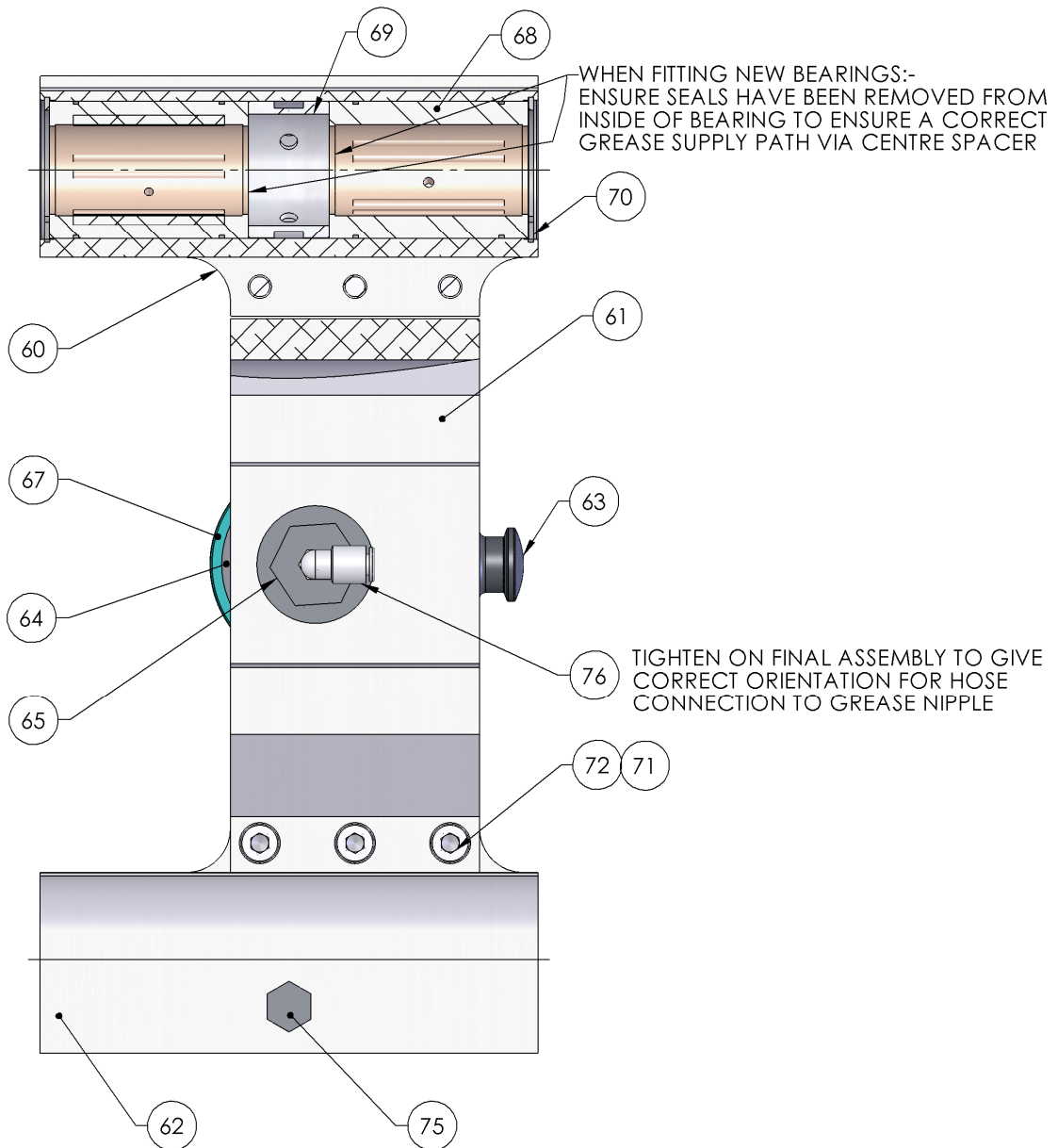

Parts List – Section 5.2

Parts List – Mechanical Assembly - Carriage 192682				
ITEM	PART No	DESCRIPTION	QTY	REMARKS
68	192642	LINEAR BEARING	4	ⓐ
69	192615	LINEAR BEARING SPACER	2	ⓐ
70	192652	Ø47 INTERNAL CIRCLIP	4	ⓐ
71	165086	M8 SPRING WASHER	6	
72	165553	M8 x 25 CAP HD SCREW	6	
73	165552	M8 x 20 CAP HD SCREW	2	
74	163152	M16 NYLOC NUT	1	
75	192649	1/8 GREASE NIPPLE - SLIP ON	2	
76	192661	1/8R - 6MM PUSH IN ELBOW	1	

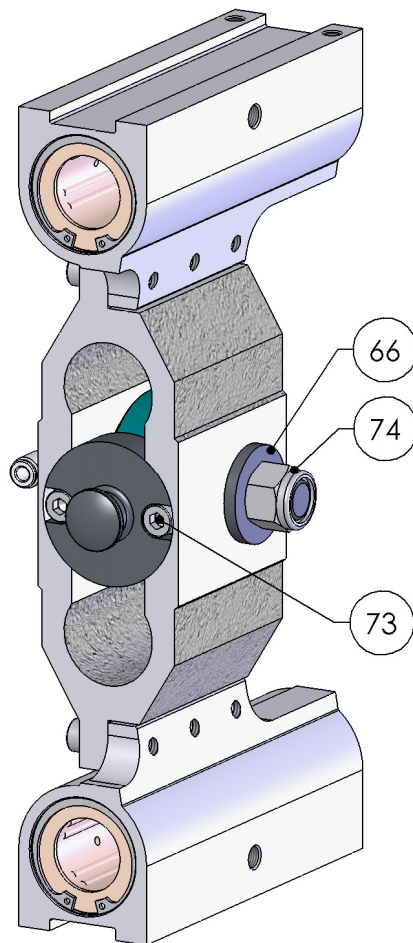

Parts List – E2-30 (192680) & E2-40 (192755) Fluid Section

ITEM	PART No	DESCRIPTION	QTY	REMARKS
80	192596	OUTLET CYLINDER	1	E2-30 PUMP
80	192789	OUTLET CYLINDER	1	E2-40 PUMP
81	192633	PISTON SEAL	1	②④ E2-30 PUMP
81	192798	PISTON SEAL	1	②④ E2-40 PUMP
82	192597	INLET CYLINDER	1	E2-30 PUMP
82	192790	INLET CYLINDER	1	E2-40 PUMP
83	192632	OUTLET SEAT	1	④
84	192595	OUTLET CHECK	1	
85	171788	1.375 BALL	1	④
86	192551	HEXAGON PLUG - 1/4 BSP	1	
87	192647	O-RING Ø50.5 x 2.62 (PTFE)	1	①②④
88	192648	O-RING Ø41.0 x 1.78 (PTFE)	1	①②④
89	192505	O-RING Ø12.42 x 1.78 (PTFE)	1	①②④
90	165960	M12 x 40 CAP HD SCREW (ST ST)	4	
91	165108	M8 SPRING WASHER (ST ST)	4	
92	164472	M8 x 25 CAP HD SCREW ST ST	4	
93	165044	M12 SPRING WASHER (ST ST)	4	
94	192626	OUTLET CAGE	1	
95	192629	INLET SPRING KEEP	2	②
96	160513	CONICAL SPRING	2	②
97	192622	Ø100 PISTON	1	E2-30 PUMP
97	192788	Ø114 PISTON	1	E2-40 PUMP
98	192623	PISTON KEEP PLATE	1	
99	192631	PISTON INLET SEAT	1	④
100	171784	1.750 ST ST BALL	1	④
101	163920	M6 x 30 CAP HD SCREW (ST ST)	5	②④
102	192646	O-RING Ø50.5 x 1.78 (PTFE)	1	①②
103	192619	PISTON SHAFT	1	
104	192579	KNIFED BELLOWS	1	③④
105	192627	BELLOWS SPACER	1	
106	192628	SHAFT SEAL	1	③④
107	192374	RETAINING NUT	1	
108	165087	M6 SPRING WASHER (ST ST)	4	
109	163921	M6 x 25 CAP HD SCREW (ST ST)	4	

Parts List – Section 5.3

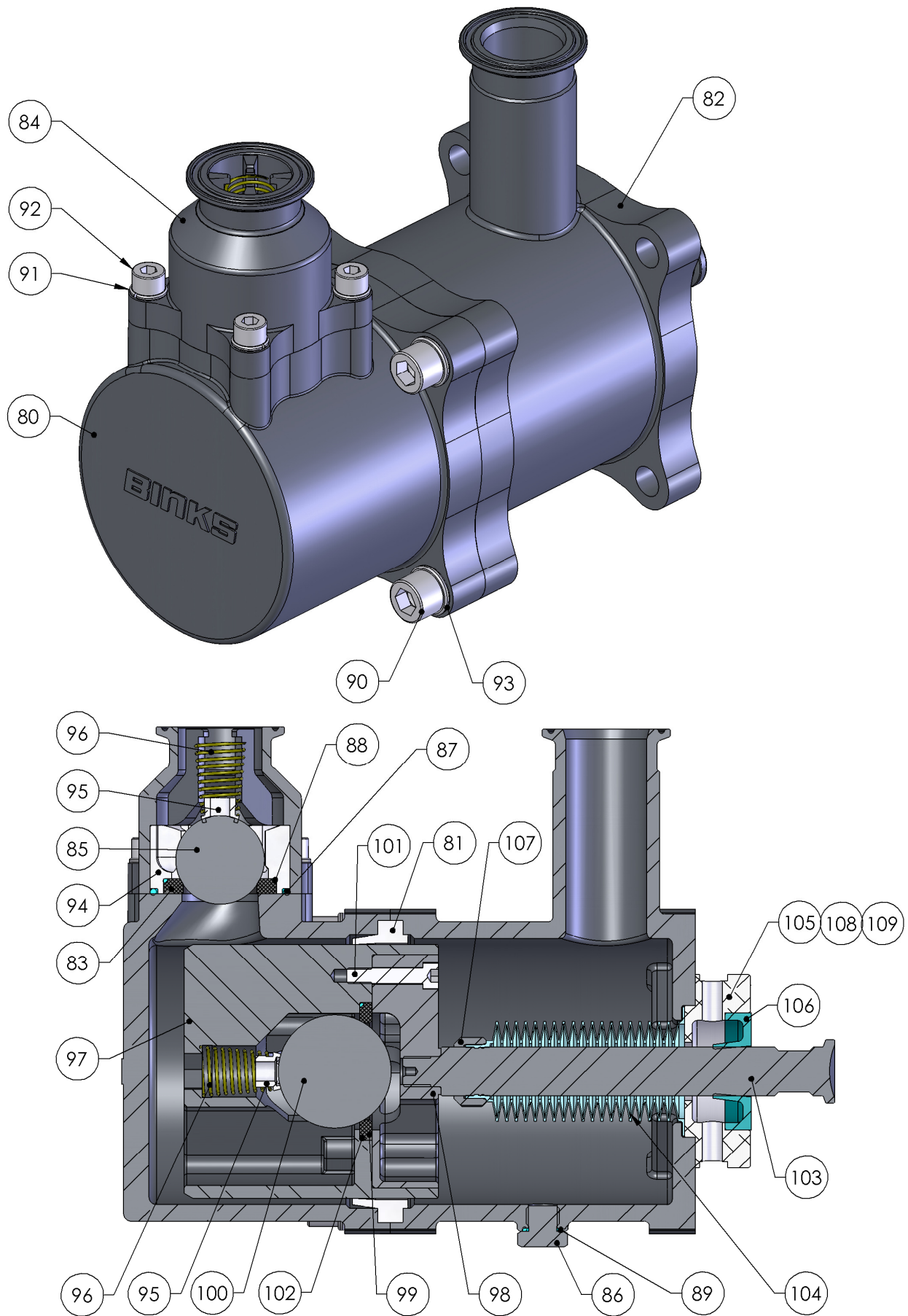

Maintenance – Section 6.1 - Assembly Procedure

Top Plate Assembly

1. Apply bearing loctite 641 to ball bearing (27) and top plate housing (11) bore. Using tool (502510) press in the bearing until the outer race rests against the shoulder in the casting bore.
2. Fit bearing cap (26) with M6 x 20 cap head screws (18) and spring washers (19) tighten to 20 Nm, apply loctite 222 to thread.

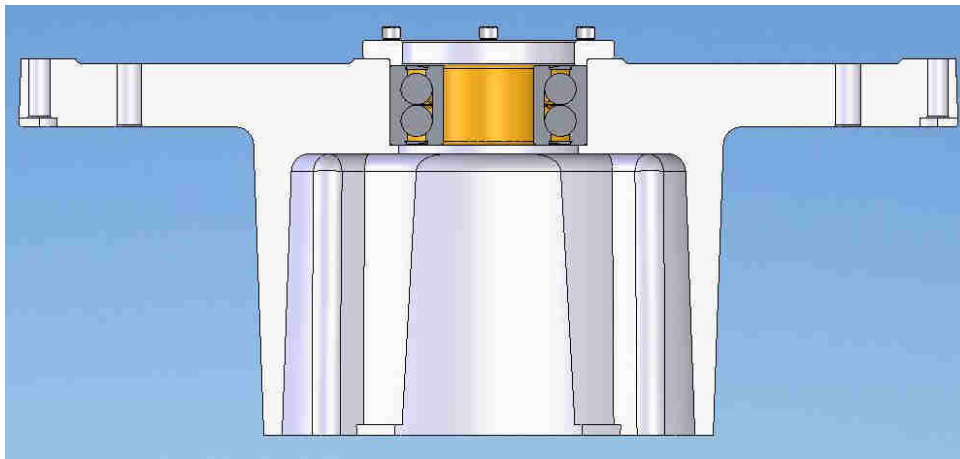

Bottom Plate Assembly

1. Lightly grease seal (21) and push seal into base plate housing (10). Note orientation of seal, 'U' cup away from bearing. (502375 grease) Remove spring from 'U' cup if fitted
2. Apply bearing loctite 641 to bearing housing and press in roller bearing (22) until outer race rests against shoulder in the casting bore, use press tool (502511). Retain the bearing inner race for later assembly to the bottom shaft.
3. Fit 4 off dowels (12) into Ø12 holes.

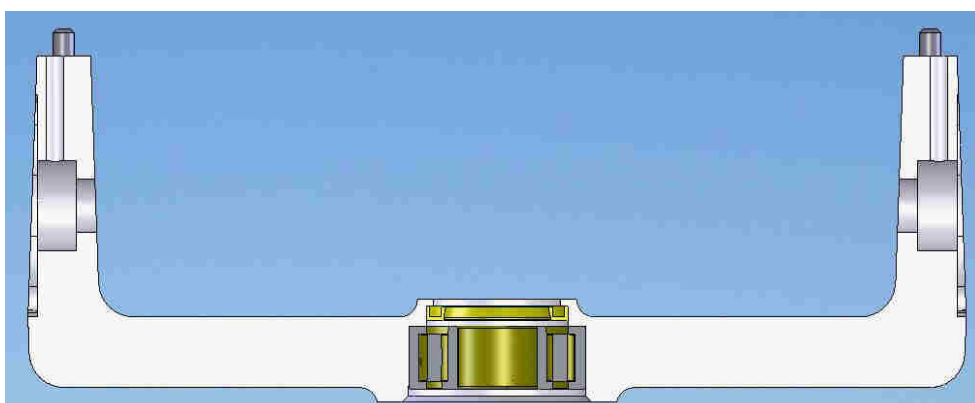

Maintenance – Section 6.1 - Assembly Procedure

Main Shaft Assembly

1. Place cam (29) onto top shaft (28) and then place base shaft (30) on top of cam.
2. Align holes and screw in M10 x 70 (17) cap head screws using loctite 243 on threads, tighten to 65Nm

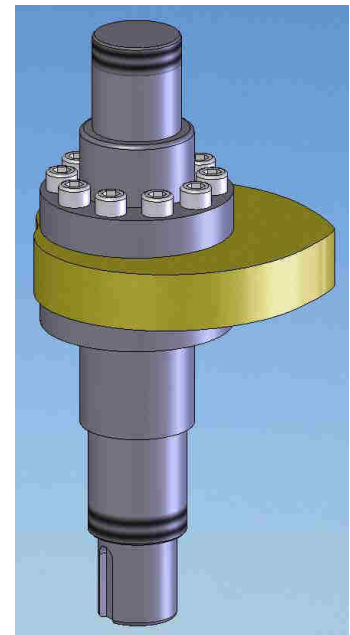

Main Drive Assembly

1. Place the top plate assembly onto a bench.
2. Clean the inner surface of bearing and shaft assembly. apply a light coating of bearing lock retainer (Typically Loctite 641)
3. Clean the Ø50 section of the shaft.
4. Place shaft assembly squarely into the bearing. The shaft should be a firm press fit to ensure inner race of bearing contacts with the Ø58 shoulder.
5. Pick up the bottom plate assembly and remove the inner race from the bearing. Fully grease the shaft seal and bearing with (502375)
6. Place the bottom plate assembly over the shaft end. Locate the dowels into the dowels holes in the top plate. Lightly grease threads and fit the M12x40 cap head screws (20), tighten to 70Nm.
7. Grease (use 502375) the inner race of the bottom bearing and the rollers of the bearing. Push the inner race over the shaft until it contacts the Ø80 shoulder. There should be at least a 0.1mm gap between the rollers and the inside edge of the inner race.
8. Light grease the M45 locking nut (31) (use 502375). Screw the nut onto the shaft and tighten using special castellated tool (502509).

Maintenance – Section 6.1 - Assembly Procedure

Main Drive Assembly

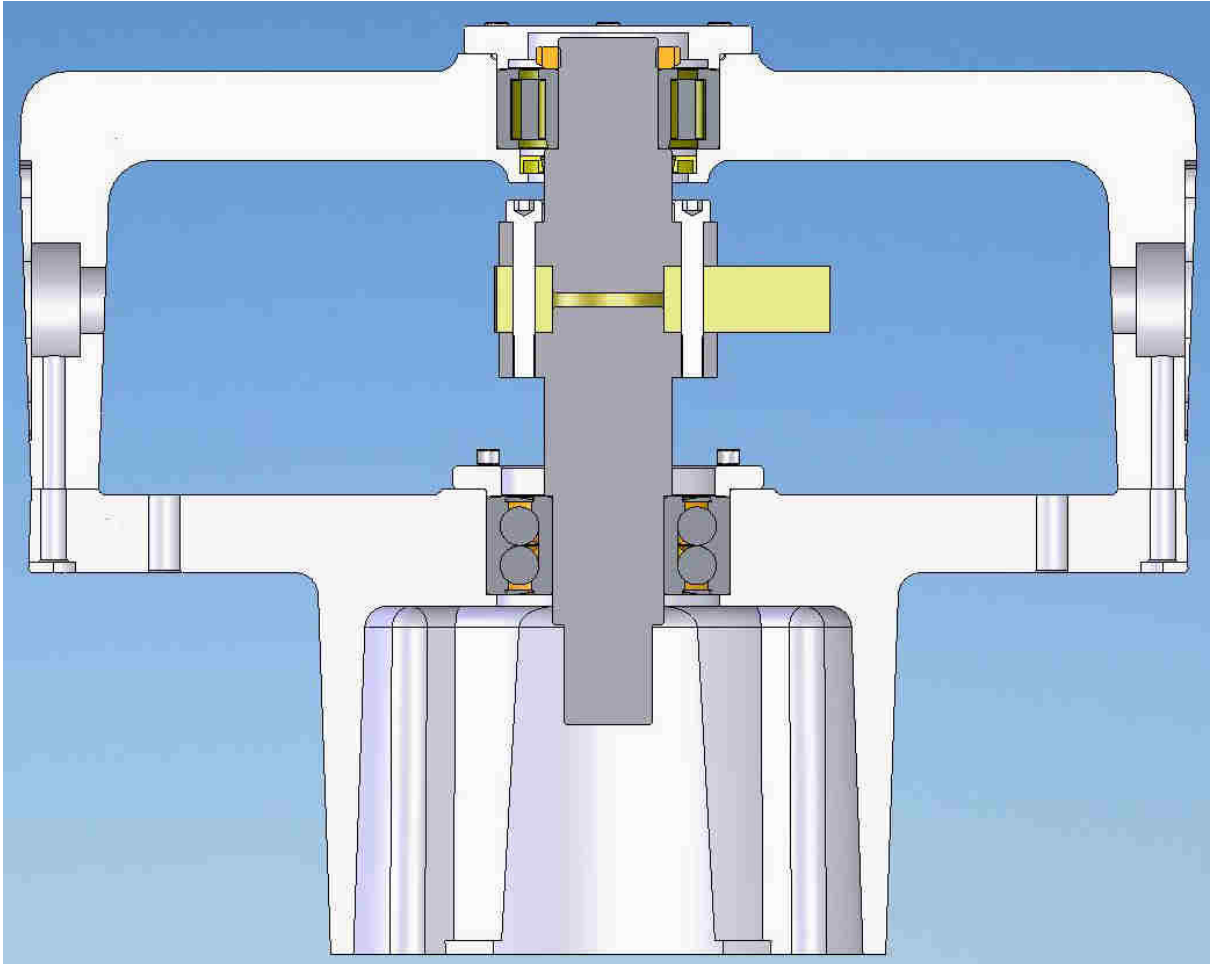

1. Place the Ø100 rubber 'O' ring (24) over the bearing cap (23) and place the cap over the end plate bearing, making sure that the greasing port is at the back of the pump assy. Fit the 6 off M6 x 20 cap screws (18) and washers (19) using Loctite 222 on the threads and tighten in a diagonal pattern until 15Nm is achieved.

2. Fit a 45° push on grease nipple (25) into the grease port, and tighten until the nipple faces the front of the pump assembly.

3. Assemble the two mounting legs (124) to the bottom plate, using M16 x 30 cap screws (126) and washers (125)

Maintenance – Section 6.1 - Assembly Procedure

192682 Carriage Sub-Assembly

End block

1. Insert grease nipple (75) into front port, corner of hexagon should point forward.
2. Insert circlip (70) into one end of block.
3. Insert linear bearing (68) into carriage so that the seal side will be on the outside the edge of the block. Orientate bearing so that the wide black section along its body is aligned to the block's side.
4. Insert white bearing spacer (69), with cross holes aligned the ball races.
5. Insert the second linear bearing (68) into carriage so that the seal side will be on the outside; orientate bearing so that the wide black section along its body is aligned to the block's side.
6. Insert the second circlip (70) to other end of the carriage block

Note: - 1 off LH (60) and 1 off RH (62) carriage blocks are required to build up one sub-assembly.

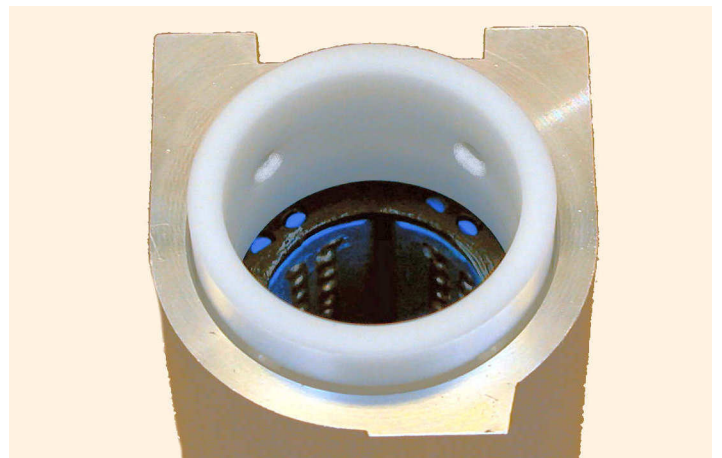
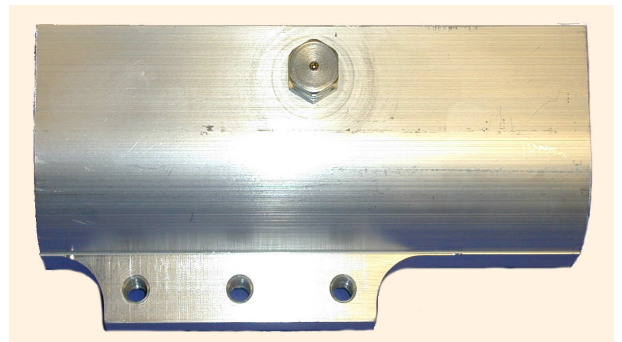
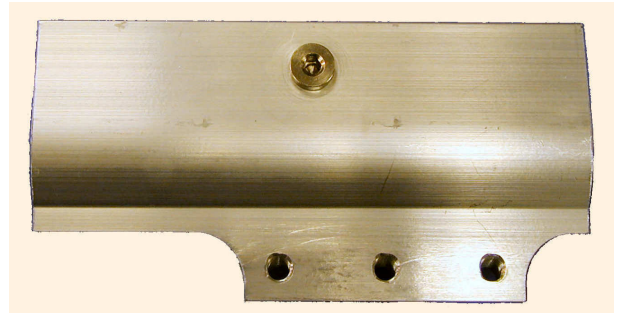

Maintenance – Section 6.1 - Assembly Procedure

192682 Carriage Sub-Assembly

1. Place cam follower pin (65) into a vice gripping the hexagon end so that the pin is vertical and the grease cross hole points towards the back.

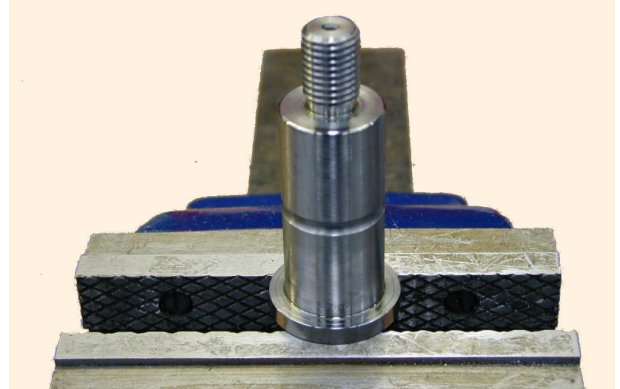

2. Place cam follower bearing (67) and one follower washer (64) each side of bearing into middle carriage (61) so that the bearing cross hole faces to the back of the block.

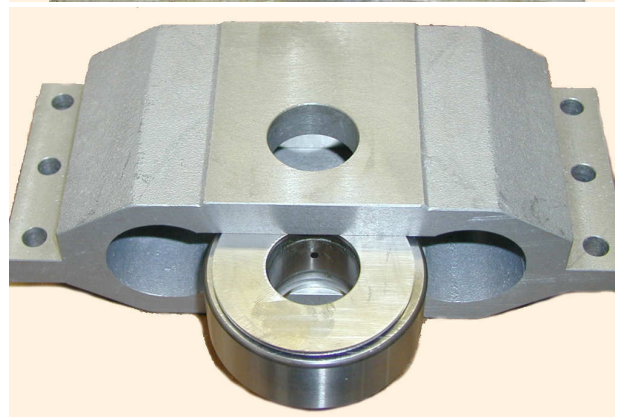

3. Place this loose assembly over the pin, so that the two cross holes line up. Place nut washer (66) and lightly greased nut (74) onto the pin. Hold in position and tighten the nut to 80 Nm.

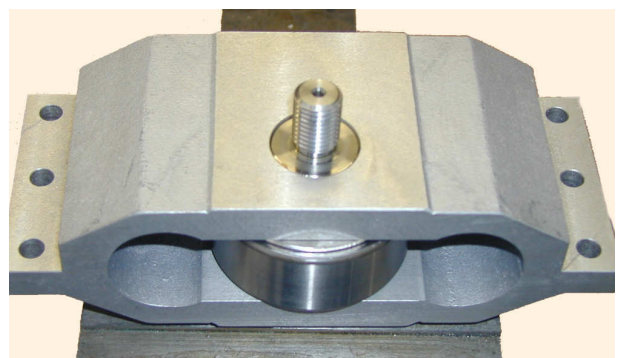

4. Place the carriage adaptor (63) in the block recess and fit 2 off screws (73) with Loctite 222 on the threads. Tighten screws to 22 Nm

5. Fit the 2 off Ø6 pushin elbows (76) into the cam follower pin grease ports and position to face the rear of the pump.

6. Assemble carriages together: - Connect 1 off LH and 1 off RH end blocks to the middle carriage (61) with 3 off per side M8 x 25 cap head screws (72) & spring washers (71) with thread lock Loctite 222. Leave the sub-assembly loose. (2 off assemblies are required.)

Maintenance – Section 6.1 - Assembly Procedure

Main Drive and Carriage Assembly

1. Apply 222 Loctite to the M8 x 30 Grub screws (15) and loosely fit into the bearing support rod clamp holes.
2. From one side 'slide in' 2 off Ø30 linear bearing support rods (34) into the carriage bar holes until they are about 25mm into the main drive.
3. Select a carriage sub-assembly and fit over the support rods (grease nipples at the top), slide the rods through the carriage assembly until they are level with the main shaft and the fitted carriage is fully back.
4. Select the other carriage sub-assembly and fit over the bearing support rods, pushing the bars into the other support rod hole. When both carriages and bars are in position tighten the M8 x 30 Grub screws (15) to 22Nm
5. Selecting one carriage at a time, slide the carriage assembly back to the side plate, pushing via the cam follower bearing (*this will align the carriage parts*). Finally tighten the cap heads M8 x 25 (72) cap head to 22Nm.
6. Check that the carriages are free to move with little or no 'stiction'.
7. Fit the 2 off Ø6 'push in' elbows into the side plate (33) front grease ports and position to face the back of the pump.
8. Push the carriages until the cam follower bearings are touching the cam.

9. Loosely assemble Spring Keeps as shown.
10. Fit 2 off spring keep assemblies to join the carriages using M8 X 20 cap head screws (14)
11. Fully tighten M8 locknuts (13) to 10Nm.

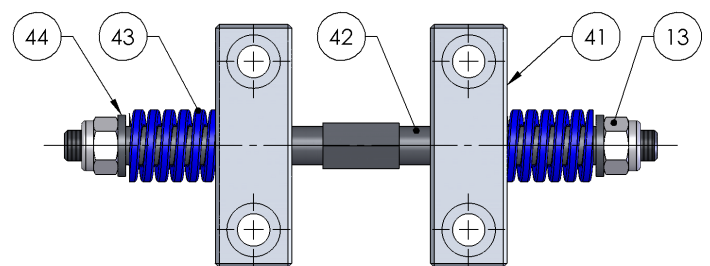

12. Rotate main drive shaft at least one turn making sure that carriage assemblies move smoothly.
13. Fit Ø6 hoses (49) to the 'push in' elbows (33) and (76)
14. With a grease gun filled with 502375 grease, pump grease into the nipple and hose (approx. 14 strokes of the grease gun), until grease comes out of the hose. Clean off excess grease and connect the hose ends to the opposite cam follower pin 'push in' fittings.

Maintenance – Section 6.1 - Assembly Procedure

Fluid Section Assembly [2] - Shaft / Bellows Assembly (192679)

1. Screw 502382 assembly spigot onto the piston shaft (103).
2. Push seal (106) and bellows spacer (105) over the piston shaft.
3. Using tool 502377 push the bellows (104) over the assembly spigot until the bellows internal spigot locates into the shaft groove.
(Using the tool prevents damage to the convolutions)
4. Smear a film of loctite 572 over the nose of the bellows then thread the nut (107) onto the bellows using tool 502377 to push against the nut ensuring the thread starts squarely. Grip the bellows and tighten the nut with a 1" A/F spanner until the nut contacts the bellows shoulder. Remove 502382 assembly spigot.

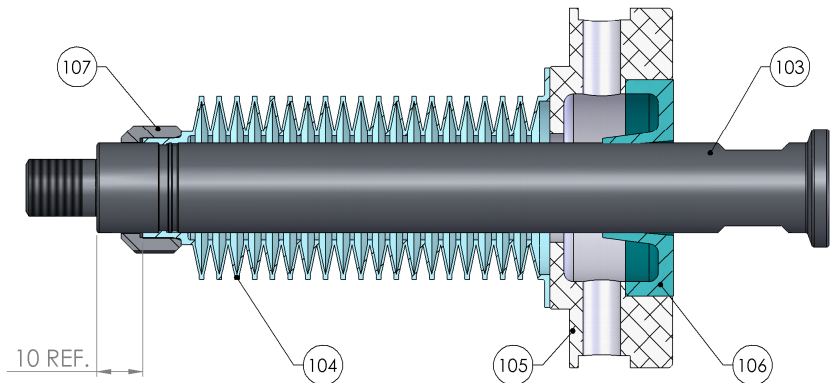

Fluid Section Assembly [2] – Piston Assembly

1. Insert spring (96) and spring keep (95) into piston
2. Place the ball (100) against spring keep.
3. Fit the 'O' ring (102) and inlet seat (99) into piston (97).
4. Fit piston keep plate (98) and assemble with 5 off M6x30 caphead screws (101) use Loctite 222 on the threads. Tighten Evenly to 12Nm.

E2-30 Piston Assembly 192678

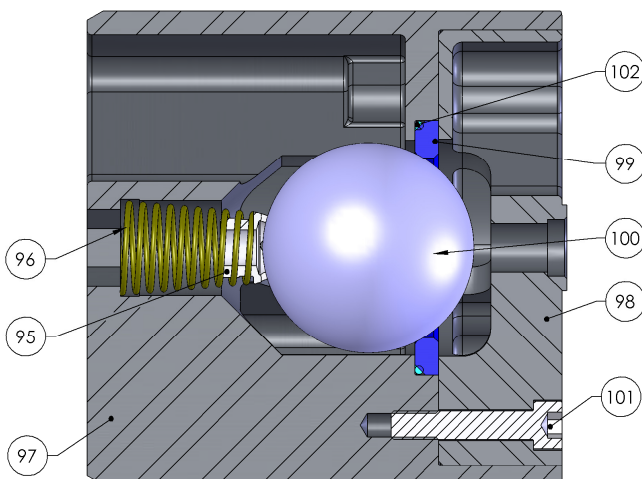

E2-40 Piston Assembly 192754

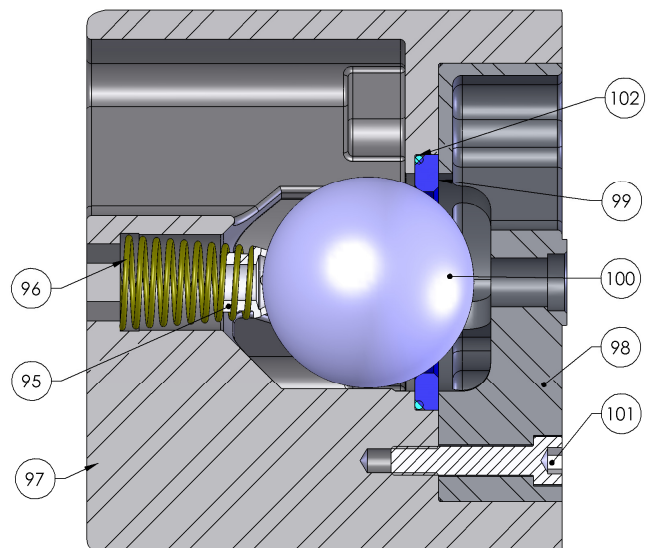

Maintenance – Section 6.1 - Assembly Procedure

Fluid Section Assembly [2]

1. Place a shaft / bellows assembly (192679) into the pocket on the back of the inlet cylinder (82). Hold in position and loosely assemble with 4 off M6 x 25 long screws (109) and washers (108) use loctite 222 on the threads.
2. Lightly lubricate with suitable grease a piston seal (81) and push the seal onto the piston assembly (192678 or 192754) with the seal lip facing away from the shaft end of the piston.
3. Apply Loctite 243 to piston shaft thread and loosely screw the Piston assembly onto the piston shaft. Locate the piston seal (81) into the inlet cylinder (82) (this *will centralize the piston*). Hold the piston and prevent from turning with 14 mm Allen key, tighten the piston onto the shaft with 16mm spanner to 55Nm. Finally tighten 4 off screws (109) to 12Nm.
4. Locate the outlet cylinder (80) over the piston seal until there is a small gap between the cylinders.
5. Lightly grease the thread of 4 off M12x40 caphead screws (90) and assemble with 4 off Ø12 washers (93) to hold the cylinders together. Tighten evenly the caphead screws in a 'criss cross' fashion to 50Nm.

6. Assemble the outlet ball checks:- place spring (96), spring keep (95) and ball (85) into outlet check (84)
7. Fit o-ring seal (88) and outlet seat (83) into outlet cage (94). Fit o-ring seal (87) onto outlet cage.
8. Fit outlet check and outlet cage assembly together and position on outlet cylinder (80).
9. Grease threads of 4 off M8x25 caphead screws (92) and washers (91) and secure. Tighten evenly to 20Nm.

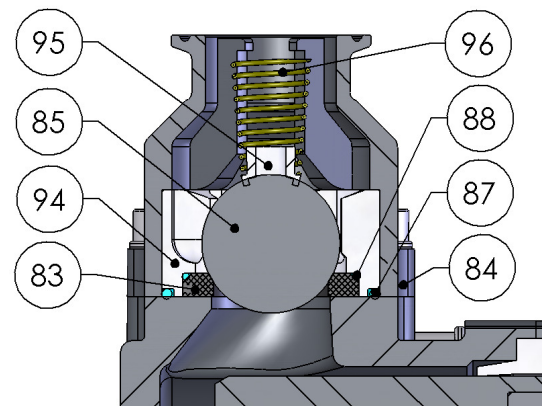

10. Fit threaded plug (86) with sealing o-ring (89)

Assemble Fluid Sections to Main Drive Assembly

1. Hold a fluid section assembly [2] and feed the piston shaft through the side of the mechanical assembly casting, locate the bellows spacer into the counterbore in the casting. Lightly grease thread of 4 off M12x40 caphead screws (128) and 8 off Ø12 washers (127) to hold the cylinders to the side plate. Tighten all caphead screw to 25Nm in 'criss cross' fashion and then to 50Nm
2. Pull the piston shaft until the shaft and the carriage adaptor are touching. Fit the quick release shaft clamp (48) and tighten to 20Nm

Maintenance – Section 6.1 – Assembly Procedure

Final Assembly

1. Use suitable lifting equipment move the pump assembly from the bench to the floor (Note: Overall weight at this point of the assembly is 180 Kg) Using suitable rope slings around the legs, turn the pump over to stand on the legs. The pump is now in the operational orientation.

2. Lightly grease and fit the shaft bearing locknut (32). Hold the main shaft and tighten nut using special castellated tool (502508).

3. Insert the 4 off m12 X 50 Grub screws (16) into the top casting, use loctite on the threads.

4. To assist with future disassembly, Brush 'copperlite' grease or equivalent onto the inside of the coupling half (39). Place the key (38) onto the main shaft and then slide the coupling half over the shaft and key, until firmly against the shaft shoulder. Apply Loctite 222 to the M8 clamping cap head screw and tighten to 22Nm. Fit the green spider into the coupling half.

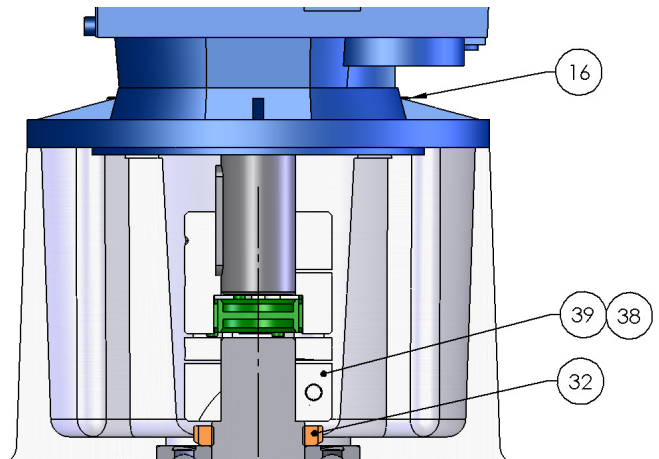

5. Brush 'copperlite' grease onto the gearbox shaft and key. Slide the other coupling half over the gearbox shaft and key until flush with the end of the shaft. (this is important as it ensures there is no axial preload on the spider and bearing) Apply loctite 222 and tighten the M8 clamping cap head screw to 22Nm.

6. Using suitable lifting equipment, lower the motor / gearbox assembly onto the pump assembly, ensure that the spider correctly locates into each coupling half. Fit the 4 off M12 hexagon nuts (123), plain washers (122), tighten to 40Nm.

7. Fit inlet manifold (129) to the pump with 1 1/2" sanitary clamps (132) and seals (131) to the orientation required.

8. Fit outlet manifold (130) to the pump with 1 1/2" sanitary clamps (132) and seals (131) to the orientation required.

9. Fit the 4 off cover spacers (36) over the grub screws (15) and fit 'O' ring (37) over cover spacers.

10. Fit the covers (133) over the cover spacer and secure with M8 Security TORX screws (134) and nylon washers (135)

11. Screw in the 2 off Lifting eye bolts (35)

12. Finally fit the bellows indication arrangement:- 2 off elbow (46) 2 off hose (47) and 1 off hose plug (45)

Maintenance – Section 6.2 - General

The working life and thus the expected life prior to replacement of parts within a Paint Pump are greatly affected by three main factors: -

- Abrasiveness of Fluid Pumped
- Pump Duty Cycle
- Fluid Pressure Output requirement

The two components which are more greatly affected by the above criteria than any other components in the pump are: The Main piston Seal and the Cam Follower ; it is therefore recommended that these two items are stocked as spare parts in addition to the recommended spare parts kits.

It is also a requirement of the E.U. ATEX directive (Use of Equipment in Potentially Explosive Atmospheres) that any Bearings should be replaced when they have reached 90% of their calculated operational life. The following chart is included as a helpful guide, as the working life of the Cam Follower bearings used in the Pump is greatly dependant upon the Duty Cycle and Fluid Pressure Output Requirement.

Before any maintenance always switch off the pump and secure against any unintentional start up.

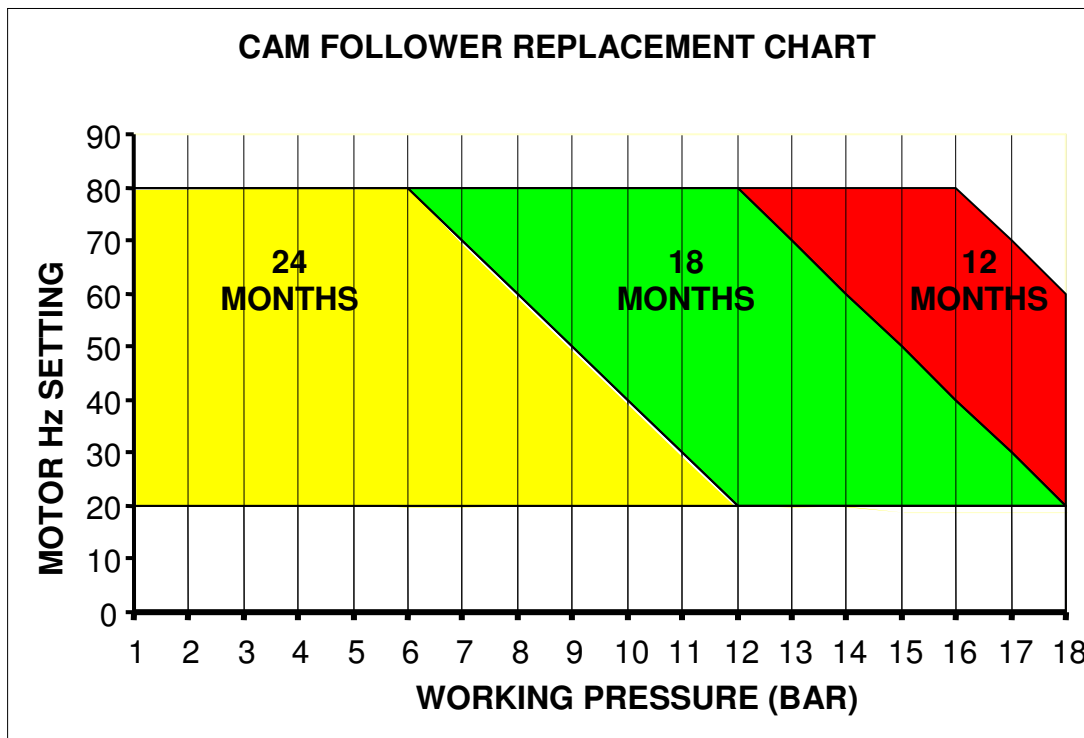

Maintenance – Section 6.2 - General

Maintenance Schedule	
Inspection	Operation
Daily	Check for any fluid leakage.
Weekly	Check for any excessive mechanical noise Check for excessive fluid pressure pulsation
3 Monthly	Grease Cam Follower Bearings (2 off) with 502375 grease. while the pump is running. Inject about 8 full strokes from a standard grease gun fitted with a standard collet connector.
6 Monthly	Grease Linear Bearings (4 off) with 502376 grease. This has to be done with the pump stopped and isolated. Inject about 15 full pumps from a standard grease gun fitted with a Hook connector. Grease Main Shaft Bearing with 502375 grease Check Gearbox Oil Level. Inspect Cam and Cam followers for excessive wear, replace if excessive wear can be seen.
Annually	Inspect Piston and Replace Piston Seals / Bellows / Springs. Inspect Piston & Outlet Ball Checks, replace as necessary. Inspect Linear Guide Bearing and Guide Rails for excessive wear. Replace gearbox oil (per ATEX regulations)
Every 5 Years	Replace main shaft bearings. Linear Guide Bearings, Guide Rails and Cams if excessive wear can be seen.
Use only 502375 (KP2N-20 DIN 51825) Grease for Cam Follower Bearing. Use only 502376 (KP2N-40 DIN 51825) Grease for Linear Guide Bearings.	

Do not mix the Cam Follower and Linear Guide bearings grease as this will reduce the operational life.

Maintenance –Section 6.2 - Initial Run Period

Following approximately 1 month running of the pump remove the cover and grease all bearings. Remove any excess grease and any dust particles present in the cam area, (Any particles present are from the cam follower tyre, this is a normal function of the bearing ‘bedding in’ with the cam surface).

Maintenance – Section 6.3 – Gearbox / Motor

Wait until the unit has cooled sufficiently after stopping and isolation.

Gearbox

Oil Plugs / Ventilator

Remove the ventilator plug prior to removing level and/or drain plug.

The gearbox is supplied factory fitted with (see chapter 1.3) oil, only 'top up' with the same type of oil and never overfill as this may cause overheating and leakage. Check the ventilator is clean and fitted correctly.

If changing the oil place a suitable container underneath the plug for draining.

Note: It is recommended that the oil should be warm (40-50° C) to facilitate easier draining.

After filling with fresh oil refit the ventilator, level and/or drain plugs and clean up any oil spillage.

Lubrication

Check the oil level every 3,000 hours or 6 months top up as necessary.

Replace gearbox oil every year as per ATEX regulations.

If Synthetic oil is used (USA Gearbox) the recommendation is to replace the oil every 3 years

Never mix different oil types.

Electric Motors

Maintenance of Ex Motors - are reported by EN 60079-17 standard, in particular:-

- The electric connections must be correctly locked to avoid resistance-increases, with consequent contact overheating.
- The insulation air-distance and the surface-distance between conductors, required by the standards, must be respected.
- All the screws, used to assemble the parts of the motors and of the terminal box, must be completely tightened.
- The replacement of seals and of components for cable entrance would be made using spare parts, supplied from the manufacturer, in order to guarantee the original type of protection.
- The Ex joint surfaces have not to be machined and it is not allowed to insert, between them, any kind of seals, not foreseen or supplied from the manufacturer. The joint surfaces have just to be cleaned and, in order to avoid corrosion or water entrance.

Repair procedures of the Ex motors - are reported by IEC 79-19 standard.

When it is not possible to make the repairs of Ex motors at the manufacturer's plant, the outside workshops, deputed to this task, must be endowed by the necessary capability, including:

- Sufficient technical knowledge of these motors.
- Factory equipment with tooling and facilities, suitable to make repairs.
- Quality control department, for the checks and the tests, requested after repairs.
- For the Ex motors the repairs of parts, directly involved on the protection against the explosion risk, must be done without any modification to the original motor design.

Fault Finding – Section 6.4

Symptom	Possible Cause	Remedy
Mechanics		
Gearbox Output shaft does not rotate, even though the motor is running.	Drive between shafts in the gear unit interrupted	Return the unit for repair and replace gearbox
Gearbox Oil leaking <ul style="list-style-type: none"> • from the gear unit cover • from the motor flange • from the gear unit flange • from the output oil seal 	a) Defective gasket on gear unit cover. b) Defective gasket. c) Gear unit not ventilated.	a) Retighten screws on gear unit cover. b) Return gearbox c) Check vent is clean/fitted and not the transportation plug
Gearbox Oil leaking from ventilator	a) Unit Overfilled with oil.	Check and correct the oil level
Cam Followers bearing generating heat / noise	Bearing needs lubrication	Grease bearing or replace if damage is too great
Carriage does not maintain contact with cam	a) Spring tension insufficient b) Fluid seal friction or piston movement prevented	Check and replace springs Check fluid section
Noisy Changeover	Coupling spider worn	Replace green spider coupling
Fluid Section		
Pump will not 'Prime'	a) Air entering the suction hose/manifold b) Worn piston seals c) Ball checks not seating correctly	a) Check o-rings and hose connections b) Replace piston seals c) Inspect, clean/replace balls/seats
Pump will not run	a) No power b) Inverter Unit or safety interlocks 'tripped'	a) Check electrical supply b) Check inverter and fault conditions
Pump runs but lack of pressure	a) Worn piston seals b) Ball checks not seating correctly	a) Replace piston seals b) Inspect, clean/replace balls/seats
Paint leaking from inside cover	Bellows seal failure	Replace bellows seal Check Piston seal, replace as necessary
Excessive Pressure Pulsation	a) Ball checks not seating correctly b) Main shaft bearings worn c) Cam follower worn d) Cam direction incorrect	a) Inspect, clean/replace balls/seats b) Replace bearings c) Replace bearings d) Ensure cam direction is clockwise

Testing and Lubricating – Section 6.5

Testing and Lubrication (Qualified personnel only)

1. Connect pump to paint system.
2. Connect electric motor to a suitable electrical supply.
3. Fit the gearbox vent plug.
4. Apply (502376) grease to linear bearings (35 strokes of a grease gun on a new bearing and 15 pumps on a bearing in current use).
5. Turn on paint system and set back pressure regulator to zero.
6. Loosen inlet cylinder vent plugs and allow the inlet air to escape from the pump. When paint starts to come out tighten the plugs back up and clean any paint spillage.
7. Turn the pump on at the local isolation mounted switch. (**Important – Never allow the pump to run with a closed ('valved off') inlet or outlet connection**)
8. Allow the pump to run for about 10 minutes between 60 to 80Hz to ensure any trapped air is correctly vented. Check for any leaks and mechanical noises.
9. While running at a slow speed apply (502375) grease to cam follower bearings
10. While running apply (502375) grease to main shaft bearing (40 strokes of a grease gun on a new bearing and 6 pumps on a bearing in current use)
11. Run the pump at 20 cycles/min (50 HZ) and increase the back pressure to 10 Bar and run for 1 hour. Check for any leaks and mechanical noises.

Fluid Drain Down

Always wear protective eyewear, gloves, clothing and respirator as recommended by the fluid and solvent manufacturer.

1. Stop the pump (turn off the electric motor); isolate the paint supply and place a suitable container underneath the hose to prevent spillage.
2. Disconnect the outlet hose and position securely into a suitable container.
3. Start the pump and run at slow speed (20Hz) for 1 minute. The pump will now have most of the paint removed; however, some material will remain within the fluid cylinders and manifolds.
4. If required to finally remove any paint from the pump, place the supply hose in a compatible solvent and run the pump until sufficiently clean.

Spare Parts List - Section 7.1

Recommended Replacement Spare Parts and Kits for E2-30 and E2-40 Pumps			
Kit No.	Part No.	Description	Remarks
#	192600	Constant Velocity Cam	
#	192622	Ø100 Piston	E2-30 Pump
#	192788	Ø114 Piston	E2-40 Pump
①	250607	Wet Section 'O' Ring kit	
②	250608	Fluid Piston Seal Kit	E2-30 Pump
②	250621	Fluid Piston Seal Kit	E2-40 Pump
③	250609	Bellows Replacement Kit	
④	250610	Wet section overhaul Kit	E2-30 Pump
④	250622	Wet section overhaul Kit	E2-40 Pump
⑤	250611	Cam Follower Bearing Kit	
⑥	250612	Linear Guide and Rod Kit	
⑦	250599	Main Bearing Overhaul Kit	
#	502672*	Cam Upgrade Kit*	
#	192688	Auto-Lubrication Kit	Cam follower Bearing
Check Main Parts List for details of individual Kit Contents			

*Pumps before serial No. 14769 will have a mark 1 constant velocity Cam fitted. If new cams are required, Cam upgrade Kit must be ordered as old Cam shape is no longer available. As the Cam is now unidirectional, the direction must be checked to ensure a clockwise motion.

Accessories - Section 8.1

Accessories / Maintenance		
Part No.	Description	Remarks
192800	Smart Card	V3.0
502371	Local Isolation Box	
502483	Electrical Panel for Single Pump Operation	Inc Smart Card
502373	Grease Gun for Cam Follower (& Main Bearings)	Collet Connector
502514	Grease Gun for Linear Bearings (300 mm Extension)	Hook Connector
502375	Grease for Cam Follower (& Main Bearings)	
502376	Grease for Linear Bearings	
502144	Pressure Switch	
192720	Sensor Manifold	
192547	Pressure Sensor (4-20 mA / 0-25 Bar)	Pressure feedback
192008	1.5 Sanitary Gasket	
192009	1.5 Sanitary Clamp	
193277	Fluid Piston Seal (PTFE)	E2-30
193278	Fluid Piston Seal (PTFE)	E2-40

Special Assembly Tools Required		
Part No.	Description of Use	Remarks
192450	M8 Torx Security Screwdriver for Cover	FOC with a New Pump
502508	Top Bearing Locknut Tool	
502509	Bottom Bearing Locknut Tool	
502510	Top Bearing Press Tool	
502511	Bottom Bearing Press Tool	
502512	Shaft Assembly Tool	
502377	Bellows Assembly Tool	
502382	Bellows Assembly Spigot	



Justus-von-Liebig-Straße 31, 63128 Dietzenbach. DE
Tel. +49 (0) 6074 403 1 Fax. +49 (0) 607 403 300
General e-mail: info@finishingbrands.eu

Ringwood Road, Bournemouth, Dorset BH11 9LH. UK
Tel. +44 (0)1202 571 111 Fax. +44 (0)1202 573 488
General e-mail: info@finishingbrands.eu

163-171, Av. des Auréats, 26014 Valence cedex. FR
Téléphone : +33 (0) 4 75 75 27 53 Télécopie: +33 (0) 4 75 75 27 79
General e-mail: info@finishingbrands.eu

USA Canada Customer Service

195 Internationale Blvd.
Glendale Height, IL 60139
630-237-5000

Toll Free Customer Service and
Technical Support 800-992-4657
Toll Free Facsimile 800-246-5732